

NOTES:

1. GEOTEXTILE TYPE VARIES DEPENDING ON SOIL CONDITIONS.
2. BLOCKS TO BE BACKFILLED WITH NATIVE BACKFILL AND SEEDED FOR VEGETATION.
3. EACH UNIT COVERS 1.5625 SQ.FT.

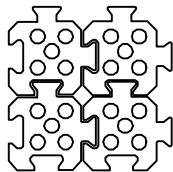

Channel-Lock II
Flexible Revetment System

EROSION PREVENTION PRODUCTS

P.O. Box 891586
Houston, TX 77289-1586
(713)947-6889

**CHANNEL LOCK II
BLOCK DETAILS**

CAD File Name:

BLOCK

SCALE: N/A

SHEET 1 OF 1

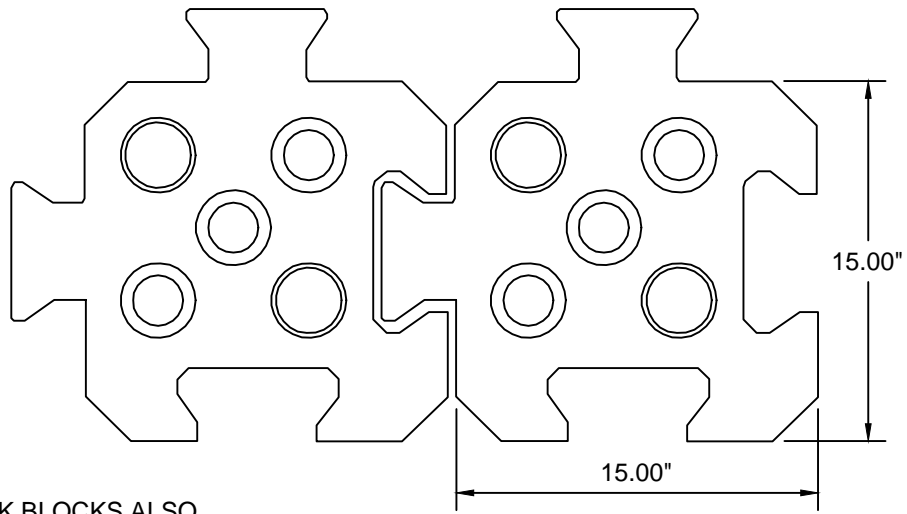
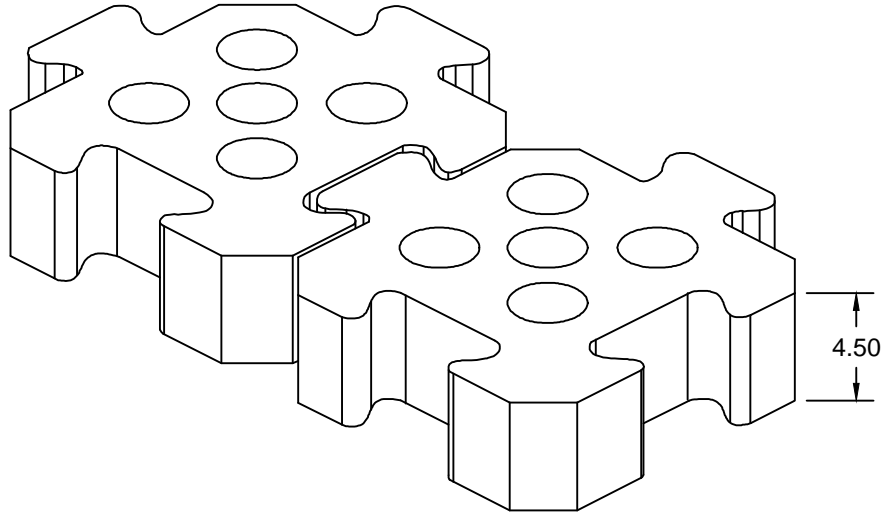

NOTES:

1. 6" AND 8" THICK BLOCKS ALSO AVAILABLE

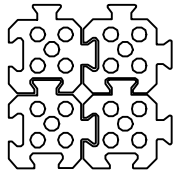

Channel-Lock II
Flexible Revetment System

EROSION PREVENTION PRODUCTS

P.O. Box 891586
Houston, TX 77289-1586
(713)947-6889

CHANNEL LOCK II
4.5" THICK

CAD File Name:

BLOCK

SCALE: N/A

SHEET 1 OF 1

45° ANGLE MAT LAYOUT

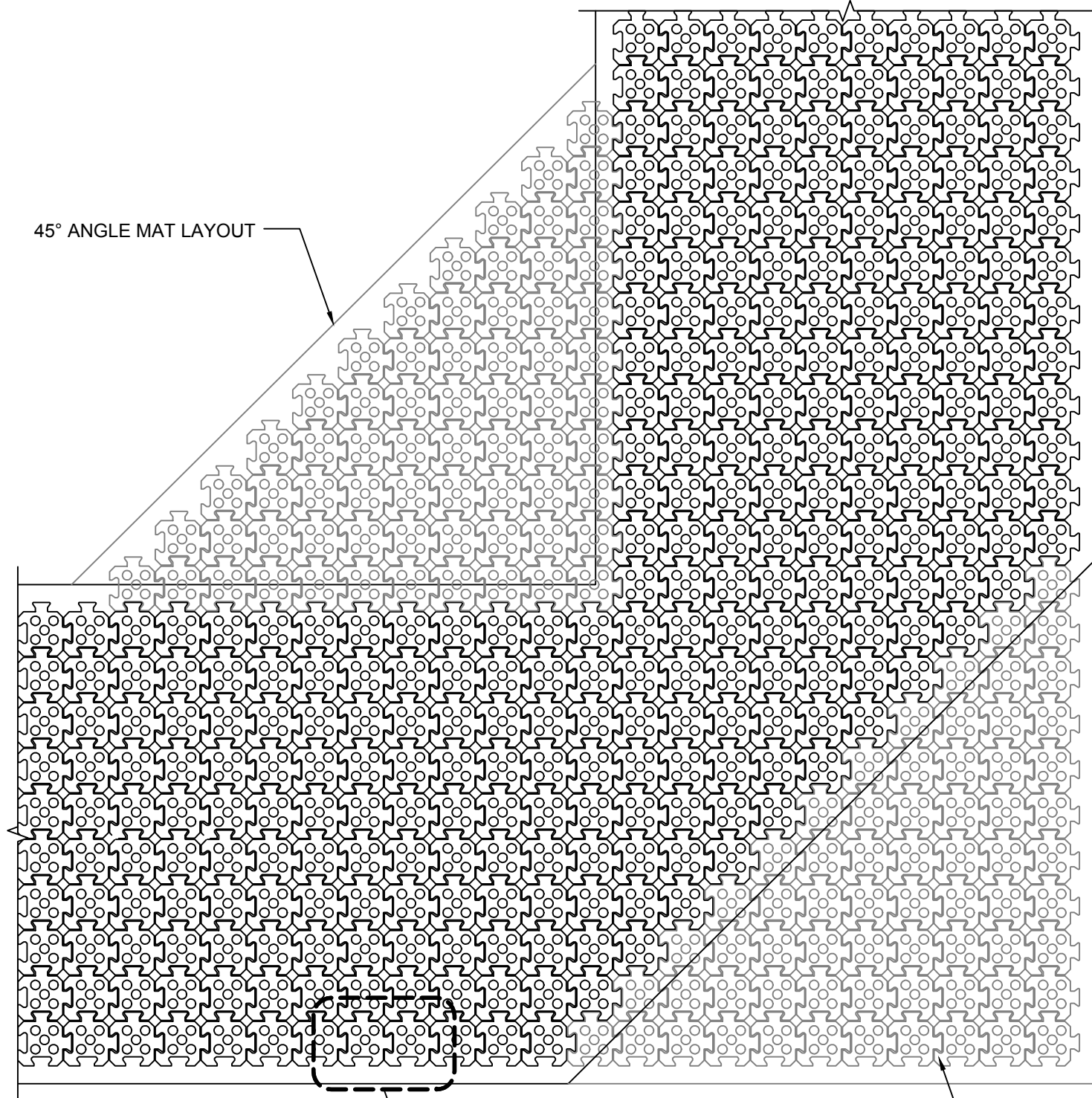

SEE ENLARGED VIEWS
(THIS SHEET)

**CHANNEL LOCK II CONNECTION
PLAN VIEW**

90° ANGLE MAT LAYOUT

GEOTEXTILE FABRIC

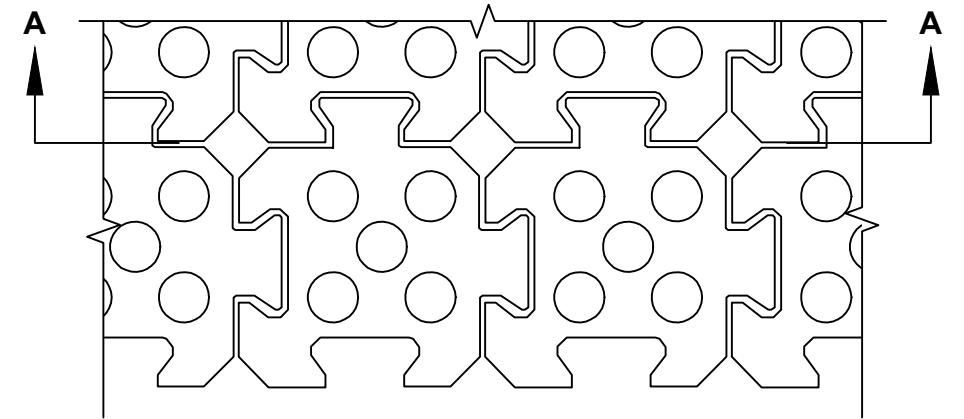

**TYPICAL MAT CONNECTION
ENLARGED PLAN VIEW**

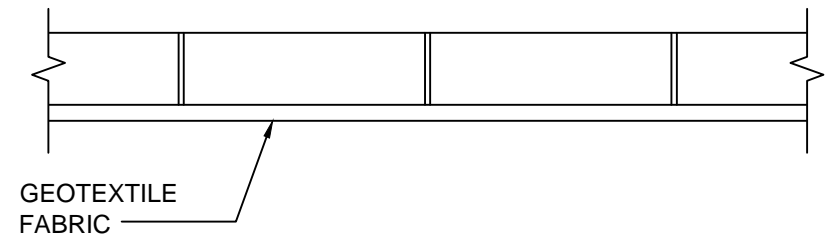

GEOTEXTILE
FABRIC

**TYPICAL MAT CONNECTION
ENLARGED SECTION VIEW**

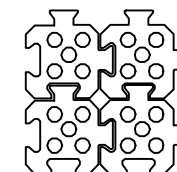

Channel-Lock II
Flexible Revetment System

EROSION PREVENTION PRODUCTS
P.O. Box 891586
Houston, TX 77289-1586
(713)947-6889

CHANNEL LOCK II CONNECTION DETAILS

CAD File Name:

ANGLEDMAT

SCALE: N/A

SHEET 1 OF 1

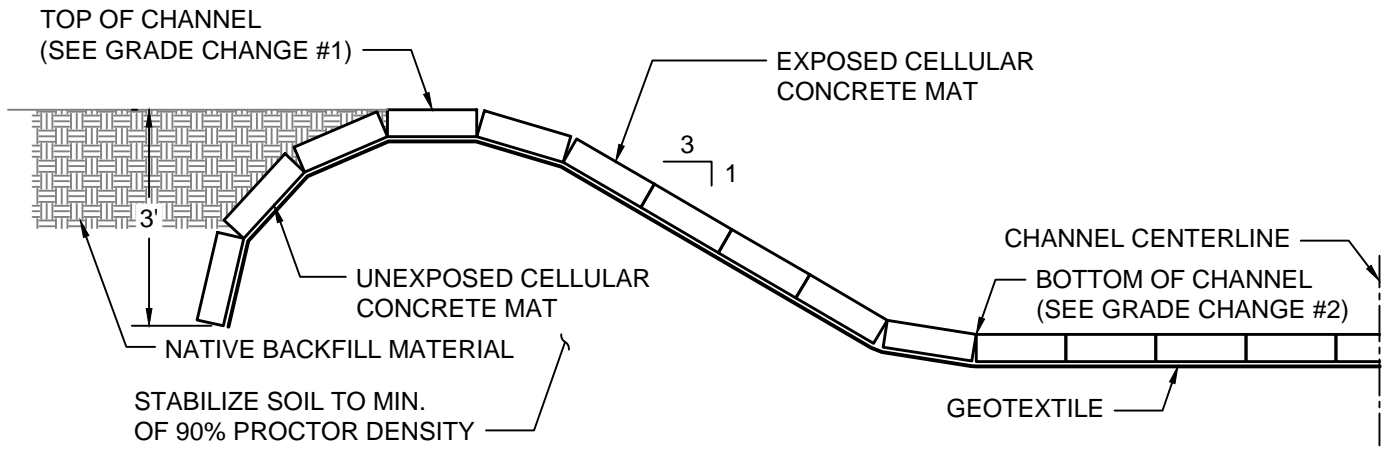

TRAPEZOIDAL CHANNEL

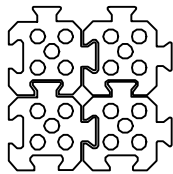
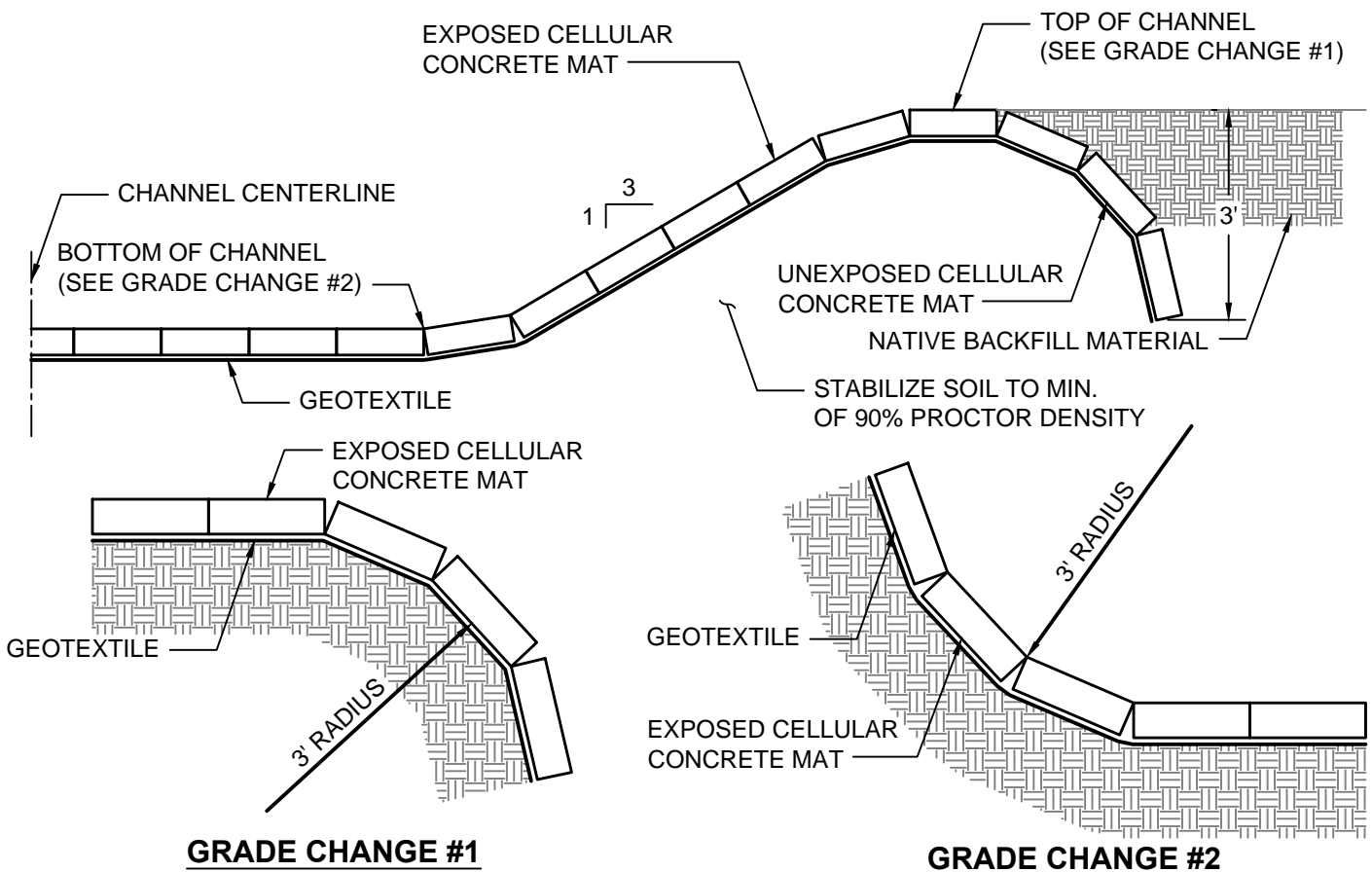

Channel-Lock II
Flexible Revetment System

EROSION PREVENTION PRODUCTS

P.O. Box 891586
Houston, TX 77289-1586
(713)947-6889

**TRAPEZOIDAL CHANNEL
DETAIL**

CAD File Name:

TRAP-CHA

SCALE: N/A

SHEET 1 OF 1

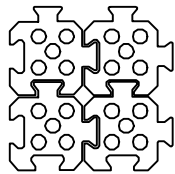
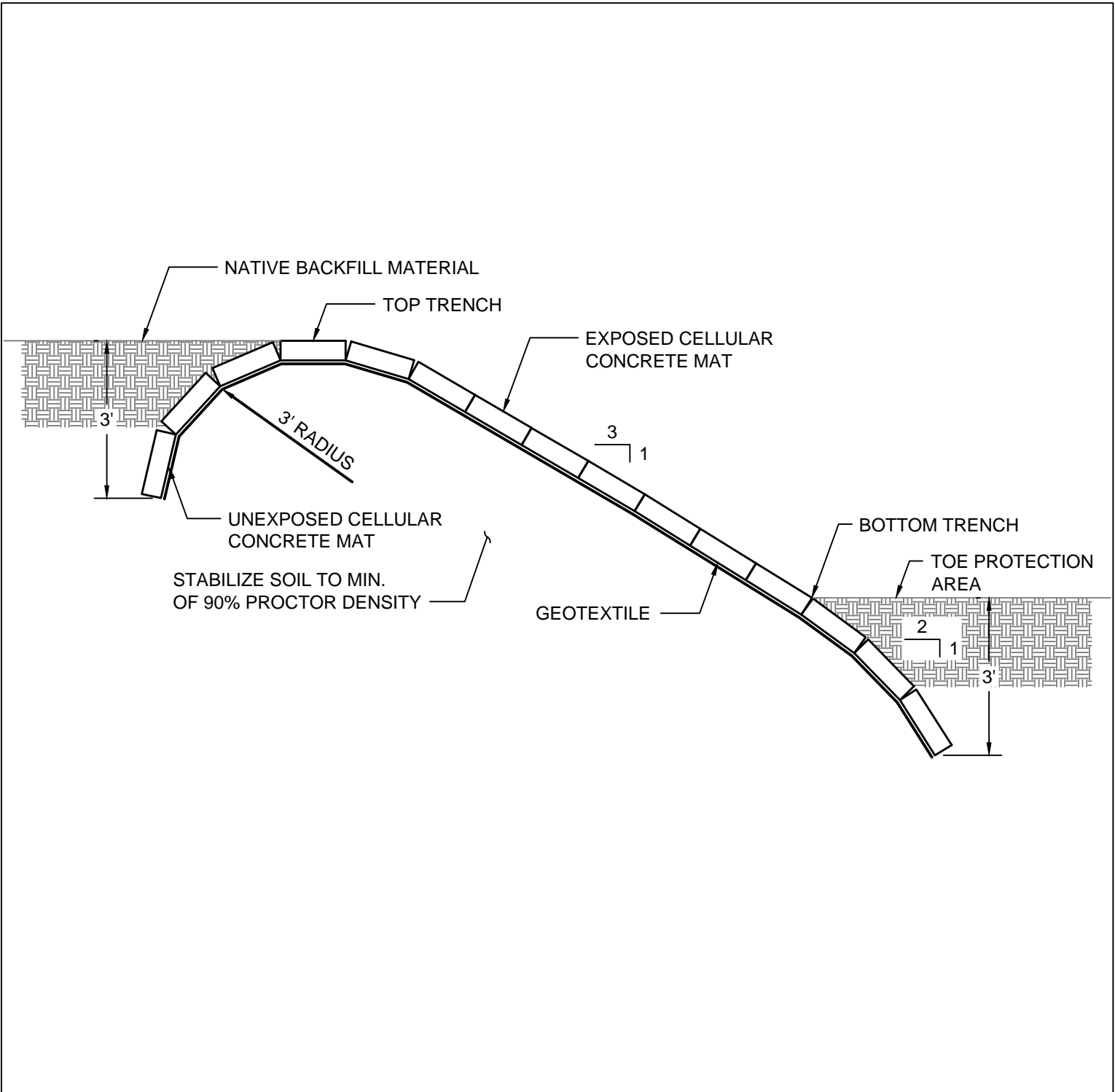

Channel-Lock II
Flexible Revetment System

EROSION PREVENTION PRODUCTS

P.O. Box 891586
Houston, TX 77289-1586
(713)947-6889

STANDARD SLOPE DETAIL

CAD File Name:

SLOPE 3 1

SCALE: N/A

SHEET 1 OF 1

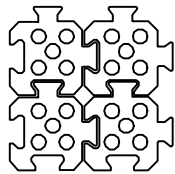
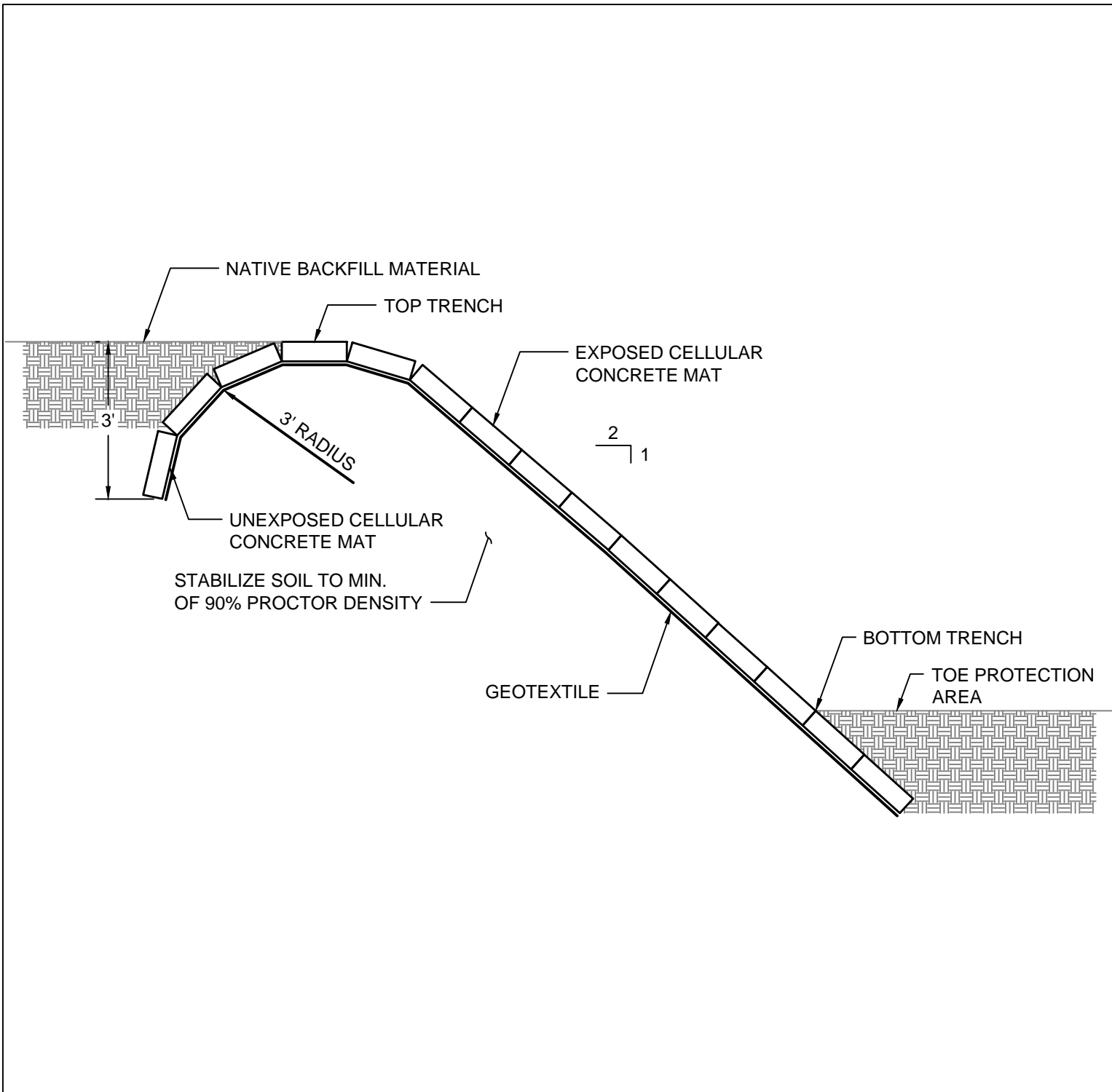

Channel-Lock II
Flexible Revetment System

EROSION PREVENTION PRODUCTS

P.O. Box 891586
Houston, TX 77289-1586
(713)947-6889

2:1 SLOPE DETAIL

CAD File Name:

SLOPE 2 1

SCALE: N/A

SHEET 1 OF 1

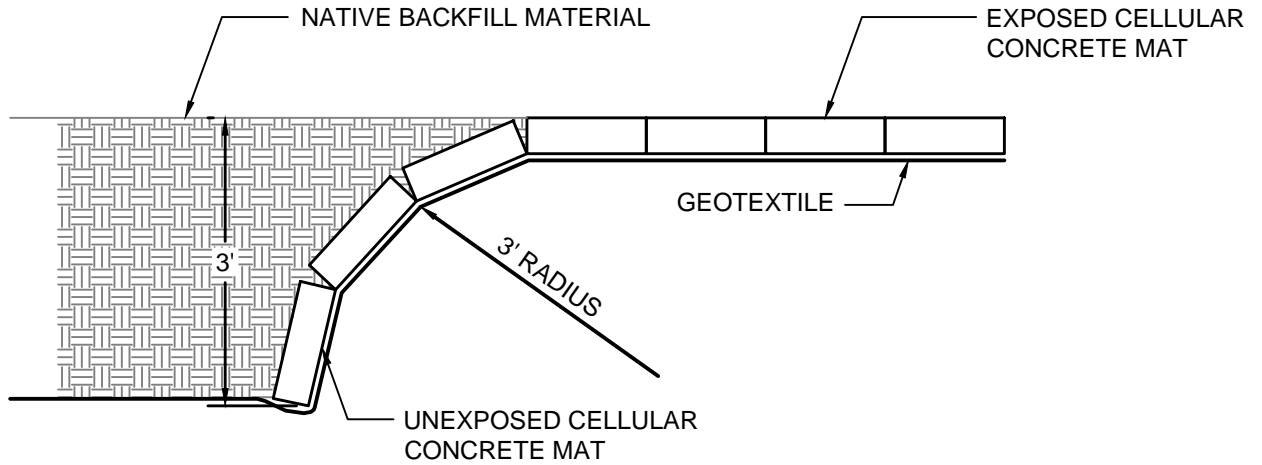

UPSTREAM FLANK

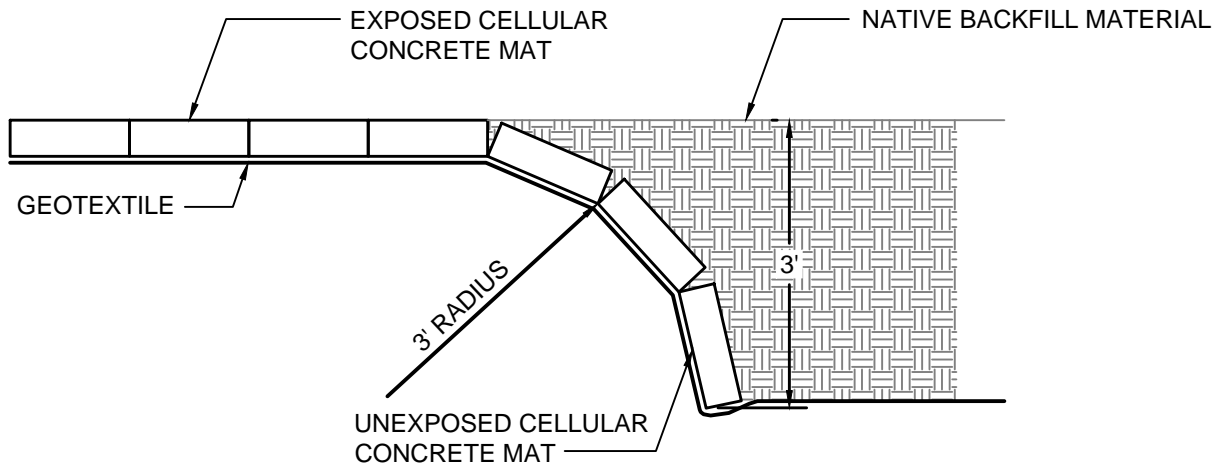

DOWNSTREAM FLANK

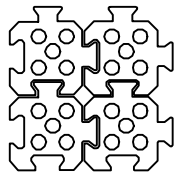

Channel-Lock II
Flexible Revetment System

EROSION PREVENTION PRODUCTS

P.O. Box 891586
Houston, TX 77289-1586
(713)947-6889

**UPSTREAM
AND DOWNSTREAM
FLANK DETAILS**

CAD File Name:

FLANKS

SCALE: N/A

SHEET 1 OF 1

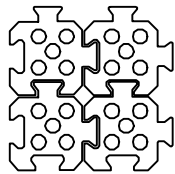
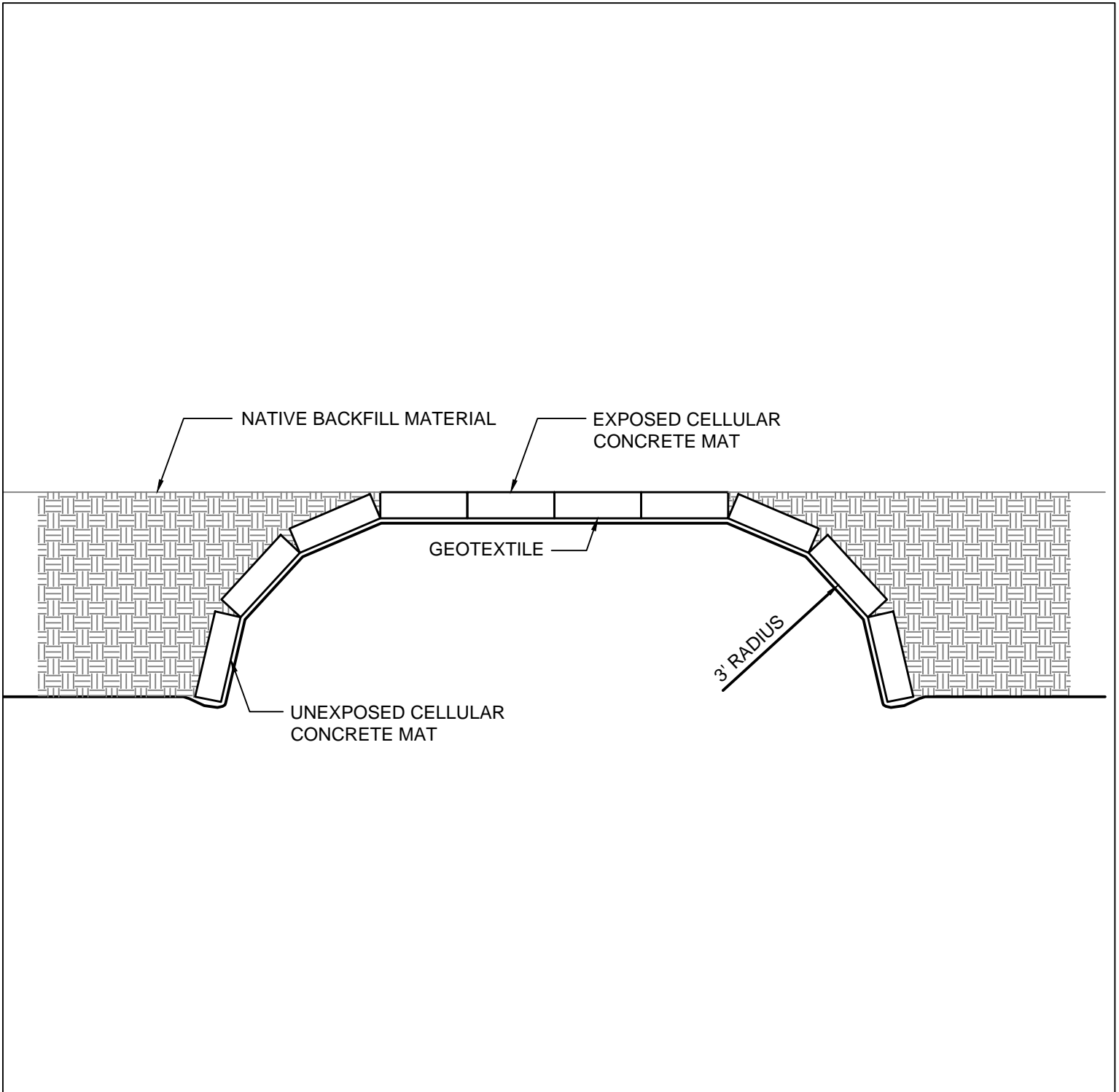

Channel-Lock II
Flexible Revetment System

EROSION PREVENTION PRODUCTS

P.O. Box 891586
Houston, TX 77289-1586
(713)947-6889

SIDE FLANK DETAILS

CAD File Name:

SIADE-FLK

SCALE: N/A

SHEET 1 OF 1

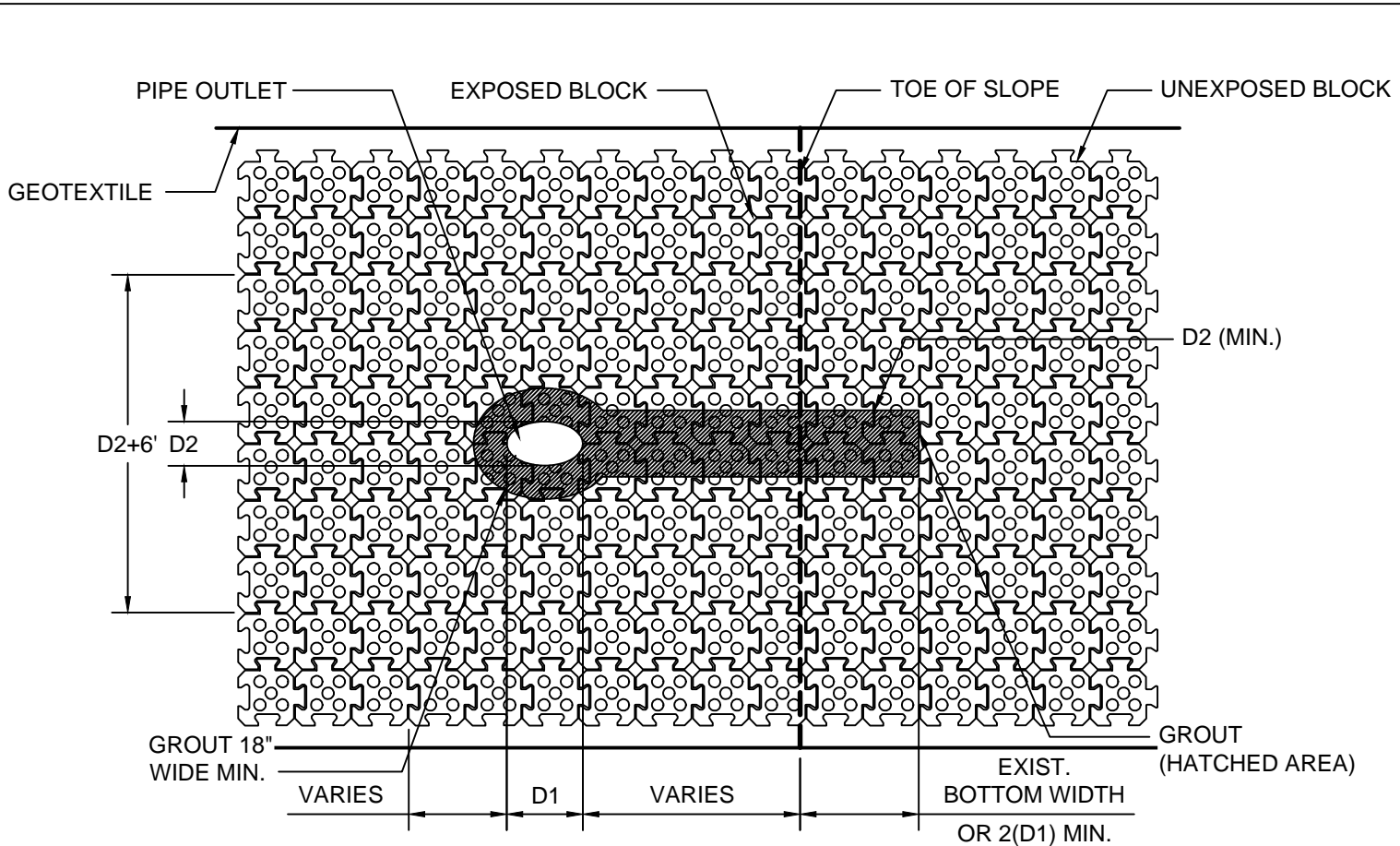

PLAN

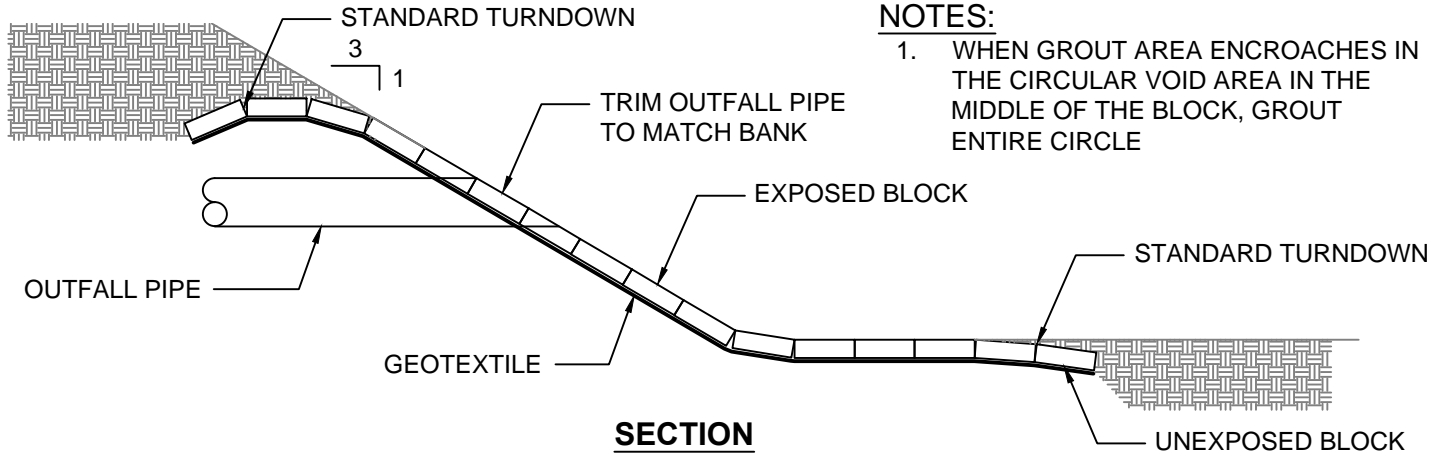

NOTES:

1. WHEN GROUT AREA ENCROACHES IN THE CIRCULAR VOID AREA IN THE MIDDLE OF THE BLOCK, GROUT ENTIRE CIRCLE

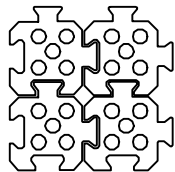

Channel-Lock II
Flexible Revetment System

EROSION PREVENTION PRODUCTS

P.O. Box 891586
Houston, TX 77289-1586
(713)947-6889

PIPE OUTLET DETAIL NO. 1

CAD File Name:

OUTFALL1

SCALE: N/A

SHEET 1 OF 1

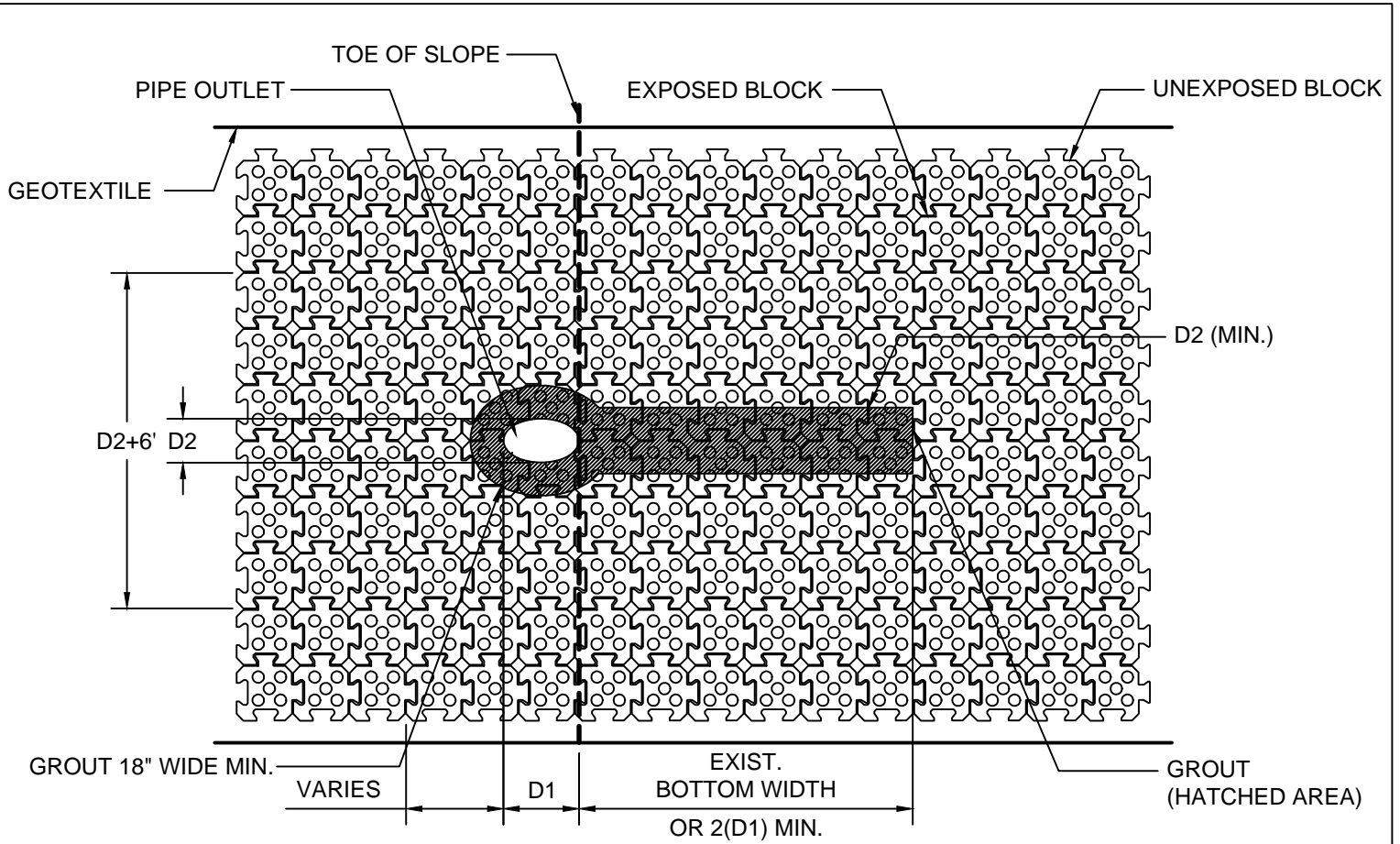

PLAN

NOTES:

1. WHEN GROUT AREA ENCREACHES IN THE CIRCULAR VOID AREA IN THE MIDDLE OF THE BLOCK, GROUT ENTIRE CIRCLE

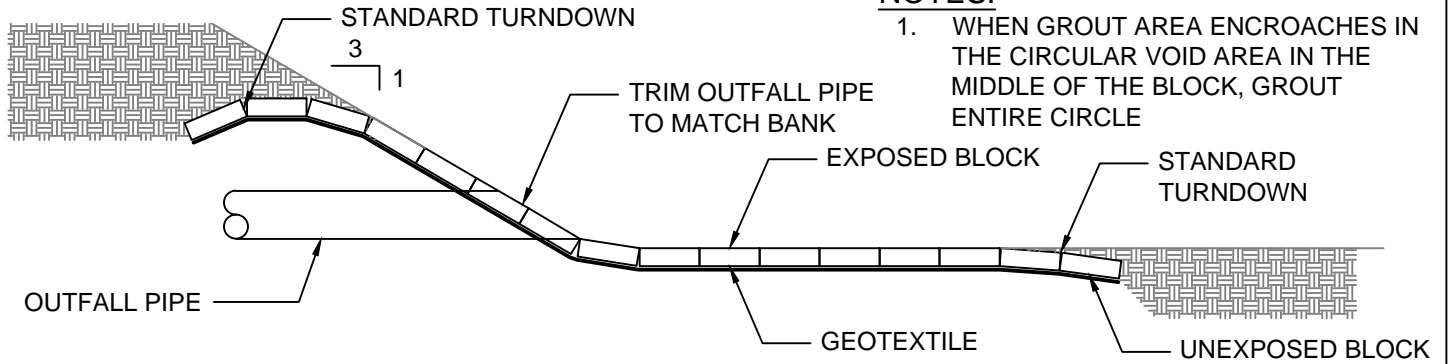

SECTION

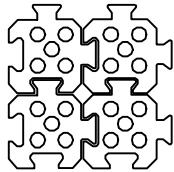

Channel-Lock II
Flexible Revetment System

EROSION PREVENTION PRODUCTS

P.O. Box 891586
Houston, TX 77289-1586
(713)947-6889

PIPE OUTLET DETAIL NO. 2

CAD File Name:

OUTFALL2

SCALE: N/A

SHEET 1 OF 1

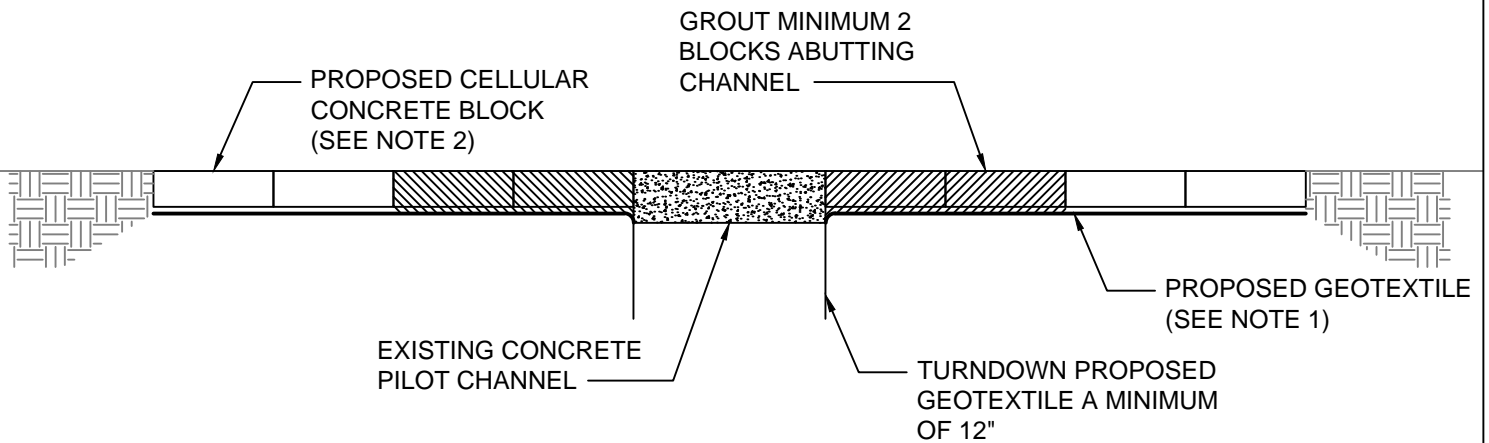

NOTES:

1. GEOTEXTILE TYPE VARIES DEPENDING ON SOIL CONDITIONS
2. BLOCKS TO BE BACKFILLED WITH TOP SOIL AND SEEDED FOR VEGETATION

SECTION

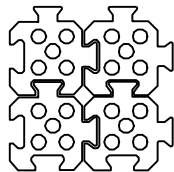

Channel-Lock II
Flexible Revetment System

EROSION PREVENTION PRODUCTS

P.O. Box 891586
Houston, TX 77289-1586
(713)947-6889

**CELLULAR CONCRETE BLOCK
ABUTTING EXISTING
CONCRETE PILOT CHANNEL**

CAD File Name:

PILOT-TIE

SCALE: N/A

SHEET 1 OF 1